

Gate, Globe & Check Valves



ASME Class 150 to 4500 | ½" to 42" (15 mm to 1050 mm)
ASME B16.34

L&T Valves manufactures engineered flow-control solutions that enhance safety, reliability and performance in flow-control systems in oil & gas, power and allied industries across the world. The company is a wholly owned subsidiary of L&T, and has a heritage of excellence that exceeds five decades.

Product Range:

- Gate, Globe & Check Valves
- Valves for Power
- Pipeline & Process Ball Valves
- Triple-offset Butterfly Valves
- Flanged & Wafer-type Butterfly Valves
- Double Block and Bleed Plug Valves
- Control Valves
- Automation Solutions including HIPPS

L&T valves are designed by specialists with deep understanding of industry requirements and practices, on state-of-the-art design and analysis software. A rigorous functional qualification and prototype test programme ensures that the customised solutions meet customer expectations.

The Quality Management System of L&T Valves is certified to comply with ISO 9001 and API Spec Q1. The company is licensed to offer products monogrammed API 600, API 6D and API 609 as well as valves with CE Marking and ATEX certification. Ball and Butterfly Valves with SIL 3 certification are also offered.

L&T Valves has three modern manufacturing units in India where cutting-edge technology and unmatched skill come together to create state-of-the-art flow-control solutions. International safety, health and environment standards govern every phase of the manufacturing process.

L&T Valves distribution network spans the globe, partnering key valve distribution companies in major industrial centres.



- Pressure-seal Range - Page No. 8
- Bolted-bonnet Range - Page No. 18
- Small Bore Valves - Page No. 24

Gate, Globe & Check Valves - Pressure-seal Range

L&T Valves manufactures a comprehensive range of Gate, Globe & Check Valves (GGC) in sizes up to 42" (1050 mm) and in ASME classes from 150 to 4500. The valves are offered in combination of size, pressure class, material, end-connection, etc., to suit myriad applications in the energy sector.

Gate Valves

Variants	ASME Class	2	3	4	6	8	10	12	14	16	18	20	22	24	26	28	30	36	38	40	42
		50	80	100	150	200	250	300	350	400	450	500	550	600	650	700	750	900	950	1000	1050
Parallel-slide	600											•	•	•	•	•	•	•	•	•	•
	900	•	•	•	•	•	•	•	•	•	•	•	•	•	•	•	•				
	1500	•	•	•	•	•	•	•	•	•	•	•	•	•	•	•	•				
	2500	•	•	•	•	•	•	•	•	•	•	•	•	•	•	•	•				
	3100	•	•	•	•	•	•	•	•	•	•	•	•	•	•	•	•				
	3500	•	•	•	•	•	•	•	•	•	•	•	•	•	•	•	•				
Flex Wedge	600	•	•	•	•	•	•	•	•	•	•	•	•	•	•	•	•	•			
	900	•	•	•	•	•	•	•	•	•	•	•	•	•	•	•	•	•			
	1500	•	•	•	•	•	•	•	•	•	•	•	•	•	•	•	•				
	2500	•	•	•	•	•	•	•	•	•	•	•	•	•	•	•	•				
	3100		•	•	•	•	•	•	•	•	•	•	•	•	•	•	•				

Globe Valves

Variants	ASME Class	2	3	4	6	8	10	12	14	16	18	20	22	24	26	28	30	36	38	40	42
		50	80	100	150	200	250	300	350	400	450	500	550	600	650	700	750	900	950	1000	1050
T Pattern	600	•	•	•	•	•	•	•	•	•	•										
	900	•	•	•	•	•	•	•	•	•	•										
	1500	•	•	•	•	•	•	•	•	•	•										
	2500	•	•	•	•	•	•	•	•	•	•										
	3100		•	•	•	•	•	•													
	3500		•	•	•	•	•	•													
Y Pattern	600	•	•	•	•	•	•	•	•	•	•										
	900	•	•	•	•	•	•	•	•	•	•										
	1500	•	•	•	•	•	•	•	•	•	•										
	2500	•	•	•	•	•	•	•	•	•	•										

Check Valves

Variants	ASME Class	2	3	4	6	8	10	12	14	16	18	20	22	24	26	28	30	36	38	40	42
		50	80	100	150	200	250	300	350	400	450	500	550	600	650	700	750	900	950	1000	1050
Swing Check	600	•	•	•	•	•	•	•	•	•	•	•	•	•	•	•					
	900	•	•	•	•	•	•	•	•	•	•	•	•	•	•	•					
	1500	•	•	•	•	•	•	•	•	•	•	•	•	•	•	•					
	2500	•	•	•	•	•	•	•	•	•	•	•	•	•	•	•					
	3100		•	•	•	•	•	•	•	•	•	•	•	•	•	•					
	3500		•	•	•	•	•	•	•	•	•	•	•	•	•	•					
Tilting Disc	900	•	•	•	•	•	•	•	•	•	•	•	•	•							
	1500	•	•	•	•	•	•	•	•	•	•	•	•	•							
	2500	•	•	•	•	•	•	•	•	•	•	•	•	•							

Gate, Globe & Check Valves - Bolted-bonnet Range

Gate Valves

ASME Class	2	2.5	3	4	5	6	8	10	12	14	16	18	20	22	24	28	30	32	34	36	38	40	42
	50	65	80	100	125	150	200	250	300	350	400	450	500	550	600	700	750	800	850	900	950	1000	1050
150	•	•	•	•	•	•	•	•	•	•	•	•	•	•	•	•	•	•	•	•	•	•	•
300	•	•	•	•	•	•	•	•	•	•	•	•	•	•	•	•	•	•	•	•	•	•	•
600	•	•	•	•	•	•	•	•	•	•	•	•	•	•	•	•	•	•	•	•	•	•	•

Globe Valves

ASME Class	2	2.5	3	4	5	6	8	10	12	14	16	18	20	22	24	28	30	32	34	36	38	40	42
	50	65	80	100	125	150	200	250	300	350	400	450	500	550	600	700	750	800	850	900	950	1000	1050
150	•	•	•	•	•	•	•	•	•	•	•	•	•		•								
300	•	•	•	•	•	•	•	•	•	•	•	•	•		•								
600	•	•	•	•	•	•	•	•	•	•	•	•	•										

Check Valves

ASME Class	2	2.5	3	4	5	6	8	10	12	14	16	18	20	22	24	28	30	32	34	36	38	40	42
	50	65	80	100	125	150	200	250	300	350	400	450	500	550	600	700	750	800	850	900	950	1000	1050
150	•	•	•	•	•	•	•	•	•	•	•	•	•		•	•	•	•		•		•	
300	•	•	•	•	•	•	•	•	•	•	•	•	•		•	•	•	•		•			
600	•	•	•	•	•	•	•	•	•	•	•	•	•		•	•	•						



Gate, Globe & Check Valves - Small Bore

Type	ASME Class	½	¾	1	1¼	1½	2	2½	3	4	6
		15	20	25	32	40	50	65	80	100	150
Globe & Check Valves	1500	•	•	•	•	•	•	•	•	•	•
	2500	•	•	•	•	•	•	•	•	•	•
	4500	•	•	•	•	•	•				



Compliance Standards

L&T Gate, Globe & Check Valves are designed in accordance with key international standards. They also meet major power industry standards and customer specifications.

Parameter		Standard	
Design	Gate Valves	ASME B16.34	API 600
	Globe Valves		API 623
	Check Valves		API 594
Ends	Face-to-face/ End-to-end Dimensions	ASME B16.10	
	End Flange Dimensions	ASME B16.5/ 16.47	
	Butt-weld End Dimensions	ASME B16.25	
	Forged Fittings, Socket welding & Threading Dimensions	ASME B16.11	
Testing		MSS SP-61 or API 598	



Materials of Construction

Material Classification	Body Materials	
	Cast Steel	Forged Steel
Carbon Steel	ASTM A216 Gr. WCB/ WCC	ASTM A105
1¼ Cr - ½ Mo	ASTM A217 Gr. WC6	ASTM A182 Gr. F11 Cl. 2
2¼ Cr - 1 Mo	ASTM A217 Gr. WC9	ASTM A182 Gr. F22 Cl. 3
9 Cr - 1 Mo - ¼ V	ASTM A217 Gr. C12A	ASTM A182 Gr. F91
Austenitic Stainless Steel 18-8 (Type 304)	ASTM A351 Gr. CF8	ASTM A182 Gr. F304
Austenitic Stainless Steel 16 Cr - 12 Ni - 2 Mo (Type 316)	ASTM A351 Gr. CF8M	ASTM A182 Gr. F316

Valves in other materials available on demand

Trim Materials

API 600 Trim	Materials			
	Stem	Seat Surface	Disc Surface	Back Seat
5	13% Cr	HF	HF	13% Cr
8	13% Cr	HF	13% Cr	13% Cr
12	SS 316	HF	SS 316	SS 316
16	SS 316	HF	HF	SS 316

Other trim combinations available on demand

Designs for L&T Gate, Globe & Check Valves are created in a 3D environment using state-of-the-art design and analysis software. Finite Element Analysis (FEA) and Computational Fluid Dynamics (CFD) are extensively used to fine-tune product designs.

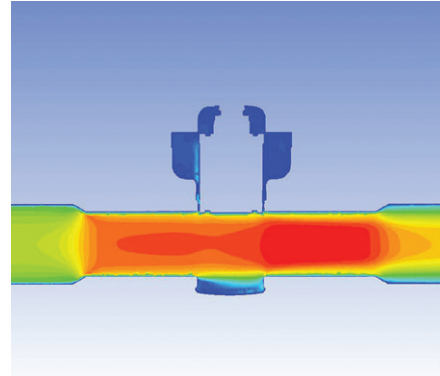
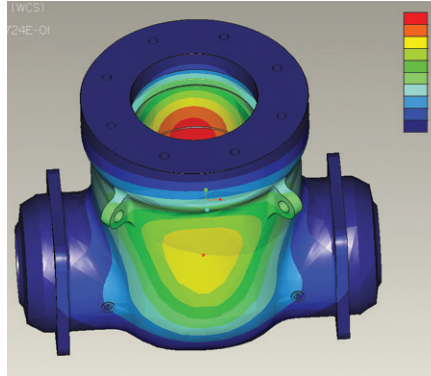

In-house Qualification Test Facilities:

- High temperature gas test
- Endurance & Cycle tests
- Seismic qualification tests
- Pipe-end load test
- Vacuum test
- Fugitive emission test

L&T Valves design team brings with them a deep understanding of user industry practices. This has aided development of valves in intermediate pressure classes as well as specialized flow-control equipment for the power industry.

L&T Valves established the reliability of its design after comprehensive prototype trials in simulated supercritical power plant conditions at its in-house test lab. The test process and results were witnessed by an independent agency.

The integrity of seat and pressure boundary of test valves (20" class 3100 WCC and 6" class 3100 C12A) were established at ambient condition, at elevated temperature and pressure as well as at re-ambient condition.

Branch Office:
TUV INDIA PRIVATE LIMITED
Classic Towers, Office No. II A,
2nd Floor, No. 1547, Trichy Road
Coimbatore - 64 1018
Tel/Fax : (0422) 4392960 / 4392070
E-mail : com@tuv-india.com
Website : www.tuvindia.co.in

High Pressure and High Temperature Gas Test	
20" Class 3100 Special Carbon Steel Gate Valve (Prototype)	
Customer: M/s Larsen & Toubro Limited Customer PO : EPIC/ES/02/1000-0025/MSV	Dated: 27.05.2010
End Client: Andhra Pradesh Power Development Corporation Limited	TUV Job No. : 8107256004
Manufacturer: M/s L&T Valves, Coimbatore	Dated : 27-Nov-2010
Test Valve Description :	
Type	Pressure Seal Gate Valve
Size and Pressure Class Rating	20" (DN 500) Class 3100 Special
Material Specification	Body Material : ASTM A216 Gr WCC Bonnet Material : ASTM A216 Gr WCC + Stellite 6 (HF) Disc Material : ASTM A105 + Stellite 6 (HF) Seat Ring Material : ASTM A105 + Stellite 6 (HF)
End Type	Butt Weld End
Reference Documents :	
Valve Test Procedure No.	LT-EP-03 Revision 2
General Assembly Drawing No	LT-HPHT-GAD-001 Revision 0
Valve Testing Arrangement Drawing No.	LT-343051 Revision 0
Valve Test Report	LT-HPHT-003
Test Parameters / Conditions : Test Fluid - Nitrogen gas	
Gas Test Pressures at Temperatures	443 bar at 194°C - Allowable Leakage Rate : 90 cc/min 519 bar at 150°C - No Pressure Drop Allowed 588 bar at ambient - Allowable Leakage Rate : 9 cc/min
Mechanical Cycles	5 Cycles at 535 bar (Ambient) - No Pressure Drop Allowed 5 Cycles at 443 bar (194°C) - No Pressure Drop Allowed
Conclusions / Remarks :	
The above valve test has been witnessed and found to be acceptable as per test procedure.	

Registered & Head Office : 801, Rajhaja Plaza - 1, L.B.S. Marg, Charkopar (W), Mumbai 400 086.
Phone : (22) 6647 7000 • Fax : (22) 6647 7009 • E-mail : mumbai@tuv-nord.com • Website : www.tuvindia.co.in

L&T Valves has three modern manufacturing facilities in India. The plants are equipped to manufacture a wide variety of critical valves for the energy sector.

Facilities:

- 5-axis Machining Centres
- CNC VTLs with table dia up to 4m
- CNC Rotary Surface Grinding Machines
- SMAW, MIG, Plasma Arc Welding Machines, table dia 60"
- EOT Cranes of capacity 40 tons

Occupational health and safety as well as environmental protection are accorded prime importance and guide all aspects of manufacturing at the plant. L&T Valves plants are zero discharge units and are pioneer in green initiatives.



Gate, Globe & Check Valves - ASME Class 600 to 4100

L&T high pressure range of gate, globe & check valves conform to ASME B16.34. The valves are of pressure-seal design and have innovative features that enhance performance and plant safety. The valves can be supplied with IBR certification.

Cast Yoke Construction

Gate and globe valves are of cast-yoke construction, where the operator is connected to the body with a robust cast yoke. Single piece cast yoke is precisely machined and located on the body neck and serves to withstand severe operating loads without compromising the alignment of the stem and operator during active performance

Pressure-seal Body-bonnet Design

In this design, line pressure is used to create a high integrity body-bonnet seal - the higher the pressure, the better the sealing. The bonnet is held in place by a split-retainer and pre-loaded against it using the bonnet bolts and retainer plate. This arrangement provides tight seal at low pressures also. Knockout holes are provided in the body for disassembly of segmental retaining ring.

Welded Seat Ring

In gate and check valves, seat rings are seal-welded to the body. This eliminates leakage path between seat ring and body as well as accidental loosening due to temperature fluctuations or vibrations.

Port Design

For gate, globe and check valves, the standard product offering is as per MSS SP-144 Style A. Adequate wall thickness and enhanced flow parameters are the characteristics of this design. Gate valves are offered in reduced-bore design also.

Hard-faced Trim

Disc, seats and back-seat (for gate and globe valves) are hard-faced with Stellite 6 or equivalent. As a standard, the valves are offered with a hard-facing thickness of 1.6 mm to ensure long and trouble-free service life.



Gate Valves

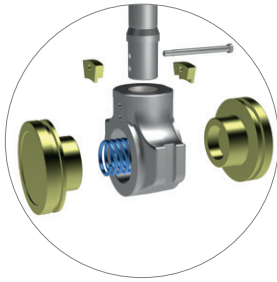

Parallel-slide Disc

The disc mechanism comprises two independent discs, a disc carrier and coil spring. The disc faces are parallel to each other and the springs keep the discs loaded against the body seats. Sealing occurs when line pressure forces the disc against the downstream seat.

Parallel-slide discs are position-seated and operating torques are considerably lower in this design. This design also eliminates chances of disc-jamming due to thermal binding.

Globe Valves

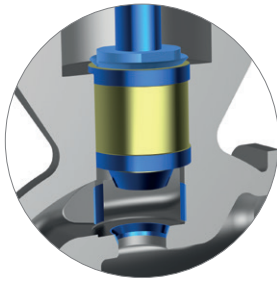

Insitu Seat

High pressure globe valves have integral seats that are machined and hardened insitu to improve wear resistance.

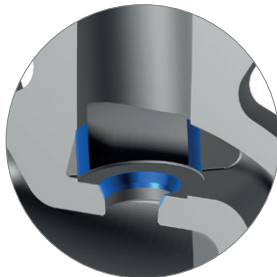

Body-guided Disc

The discs of L&T globe valves are guided during opening/ closing to minimise effects of side thrust and this prevents seat damage.

Disc Options

Tapered Disc (Quick-opening Disc)

Tapered Disc design is offered as a standard. In this design, when the valve is opened, close-to-maximum discharge is obtained very quickly. These valves are used in services that require quick opening.

Special Profile Discs

- Linear Characteristic Disc
- Equal Percentage Disc

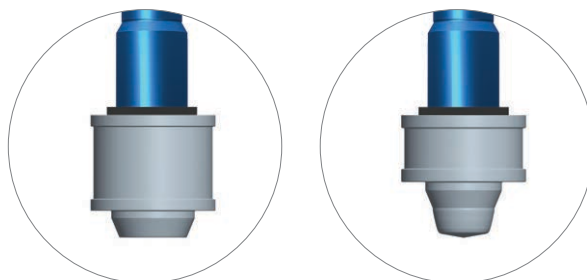

Gate Valves - ASME Class 600 to 4100 (ASME B16.34)

L&T gate valves in classes ranging from 600 to 4100 conform to ASME B16.34. The valves feature a high integrity pressure-seal body-bonnet connection and are of cast-yoke construction. The valves are offered in Parallel-slide and Flex Wedge designs.

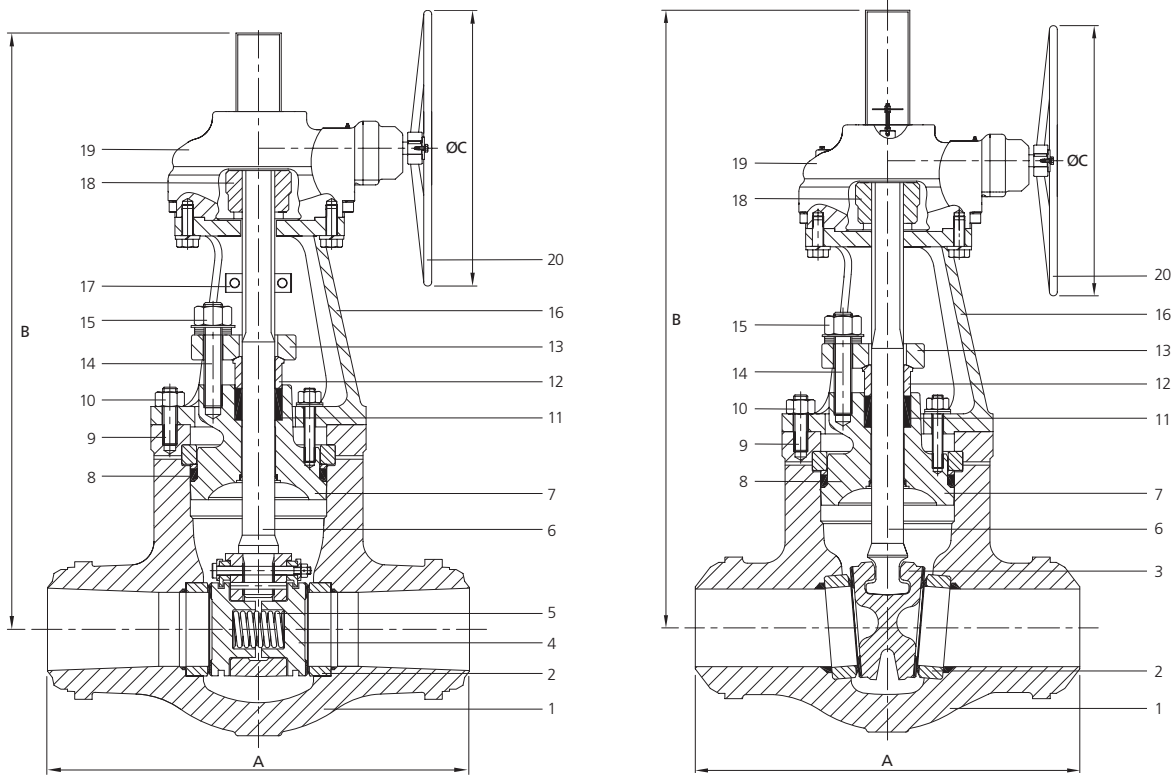

Materials of Construction

No.	Components	Materials			
		WCC	WC6	WC9	C12A
1	Body	A216 Gr. WCC	A217 Gr. WC6	A217 Gr. WC9	A217 Gr. C12A
2	Seat Ring (Seal Welded)	A105N + HF	A182 Gr. F11 + HF	A182 Gr. F22 + HF	A182 Gr. F91 + HF
3	Wedge (Flexible)	A216 Gr. WCC + HF	A217 Gr. WC6 + HF	A217 Gr. WC9 + HF	A217 Gr. C12A+ HF
4	Disc	A105N + HF	A182 Gr. F11 + HF	A182 Gr. F22 + HF	A182 Gr. F91 + HF
5	Spring	Inconel X750			
6	Stem	A182 Gr. F6a	A182 Gr. F6a	A182 Gr. F6a	A479 Type XM-19
7	Bonnet	A216 Gr. WCC/ A105N + HF	A217 Gr. WC6/ A182 Gr. F11 + HF	A217 Gr. WC9/ A182 Gr. F22 + HF	A217 Gr. C12A/ A182 Gr. F91 + HF
8	Gasket	Graphite			
9	Stud	A193 Gr. B7	A193 Gr. B16	A193 Gr. B16	A193 Gr. B16
10	Hex Nut	A194 Gr. 2H	A194 Gr. 7	A194 Gr. 7	A194 Gr. 7
11	Packing	Graphite with Braided end-rings			
12	Gland	A276 Type 410	A276 Type 410	A276 Type 410	A276 Type 316
13	Gland Flange	A216 Gr. WCC/ A105N	A217 Gr. WC6/ A182 Gr. F11	A217 Gr. WC9/ A182 Gr. F22	A217 Gr. C12A/ A182 Gr. F91
14	Stud	A193 Gr. B7	A193 Gr. B16	A193 Gr. B16	A193 Gr. B16
15	Hex Nut	A194 Gr. 2H	A194 Gr. 7	A194 Gr. 7	A194 Gr. 7
16	Yoke	A216 Gr. WCC	A217 Gr. WC6	A217 Gr. WC9	A217 Gr. C12A
17	Stem Guide	A276 Type 410			
18	Stem Nut	Bronze			
19	Gear Unit	Ductile Iron			
20	Handwheel	Steel			
--	Identification Plate	SS 304			

HF - Hard-Faced with Stellite 6 or equivalent

Parallel-slide Gate Valves - Dimensions & Weights

Size		Class 900				Class 1500				Class 2500				Class 3100			
NPS	DN	A	B	C	Wt.	A	B	C	Wt.	A	B	C	Wt.	A	B	C	Wt.
3	80	305	580	305	65	305	580	305	65	368	580	500	130	368	710	400	140
4	100	356	710	355	110	406	610	400	120	457	580	500	165	457	785	400	280
6	150	508	670	630	235	559	710	630	270	610	765	710	350	610	1090	710	545
8	200	660	815	710	380	711	825	710	500	762	930	800	690	762	1200	900	925
10	250	787	1025	900	720	864	1025	900	900	914	1020	900	1250	914	1420	800	1470
12	300	914	1105	900	1000	991	1110	900	1100	1041	1440	1000	1900	1041	1661	800	2340
14	350	991	1150	900	1200	1067	1320	1000	1700	1118	1600	1000	2900	1118	1715	800	3400
16	400	1092	1560	1000	1660	1194	1600	1000	2250	1245	1910	800	3900	1245	1890	800	4000
18	450	1219	1945	800	2500	1346	1680	1000	3470	1397	2220	900	4620	1397	2200	900	5540
20	500	1321	2150	800	2950	1473	1980	1000	4550	1537	2550	800	6760	1524	2390	1000	7130
24	600	1549	2550	800	4225	1943	2570	1000	6600	1549	2920	900	8760				
28	700	1727	2775	1000	6300												

Size		Class 600			
NPS	DN	A	B	C	Wt.
20	500	1194	1855	800	2320
22	550	1250	2045	800	3100
24	600	1397	2380	800	3535
26	650	1448	2520	800	4600
28	700	1549	2695	800	5345
30	750	1651	2835	900	7700
36	900	1900	3375	1000	9500
38	950	1900	3415	1000	11500
40	1000	1900	3855	900	14000
42	1050	1900	3960	1000	16500



Flex Wedge Gate Valves - Dimensions & Weights

Size		Class 600				Class 900				Class 1500				Class 2500			
NPS	DN	A	B	C	Wt.	A	B	C	Wt.	A	B	C	Wt.	A	B	C	Wt.
2	50	292	405	203	25	216	470	228	40	216	460	228	40	279	445	228	55
3	80	254	545	254	45	305	590	305	65	305	615	356	75	368	850	500	150
4	100	305	690	305	80	356	690	356	110	406	810	500	145	457	810	500	190
6	150	457	900	508	350	508	1105	710	250	559	1110	710	330	610	1140	710	520
8	200	584	1200	500	300	660	1290	710	380	711	1360	800	680	762	1400	900	1100
10	250	711	1455	710	720	787	1445	800	720	864	1580	900	1000	914	1720	1000	2100
12	300	838	1680	710	1150	914	1810	900	1150	991	1810	1000	1580	1041	1830	1000	2205
14	350	889	1815	800	1165	991	1925	900	1420	1067	2015	1000	2200	1118	2030	1000	3400
16	400	991	2140	900	1510	1092	2145	1000	2000	1194	2215	1000	2750	1245	2240	1000	4600
18	450	1092	2270	710	2650	1219	2260	800	2650	1346	2300	900	3915	1397	2410	900	5500
20	500	1194	2630	1000	3040	1334	2600	900	4270	1473	2590	900	5150	1473	2650	1000	6980
24	600	1397	2850	710	5100	1549	3410	1000	5100	1943	3070	900	7500	1549	3070	1000	10600
30	750	1651	3625	1000	6600	1816	3770	900	6600	2229	3700	710	13500				
32	800	1778	3850	1000	8550	1778	3855	1000	10975								
36	900	2083	4100	1000	10500												

All dimensions in mm and weights in kg

Globe Valves - ASME Class 600 to 3500 (ASME B16.34)

L&T manufactures high-pressure globe valves in ASME classes ranging from 600 to 3500. These valves conform to ASME B16.34 and feature a pressure-seal body-bonnet connection.

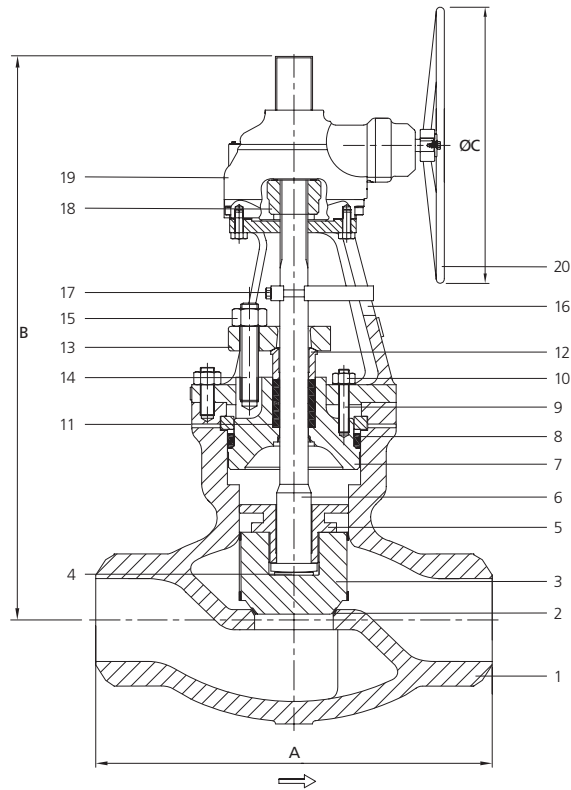

Materials of Construction

No.	Components	Materials			
		WCC	WC6	WC9	C12A
1	Body	A216 Gr. WCC + HF	A217 Gr. WC6 + HF	A217 Gr. WC9 + HF	A217 Gr. C12A+ HF
2	Seat	Insitu on Body + Stellite #6			
3	Disc	A182 Gr. F6a/ A105N + HF	A182 Gr. F11 + HF	A182 Gr. F22 + HF	A182 Gr. F91 + HF
4	Disc Washer	A276 Type 410			
5	Disc Nut	A276 Type 410			
6	Stem	A182 Gr. F6a	A182 Gr. F6a	A182 Gr. F6a	A479 Type XM-19
7	Bonnet	A216 Gr. WCC/ A105N + HF	A217 Gr. WC6/ A182 Gr. F11 + HF	A217 Gr. WC9/ A182 Gr. F22 + HF	A217 Gr. C12A / A182 Gr. F91 + HF
8	Gasket	Graphite			
9	Stud	A193 Gr. B7	A193 Gr. B16	A193 Gr. B16	A193 Gr. B16
10	Hex Nut	A194 Gr. 2H	A194 Gr. 7	A194 Gr. 7	A194 Gr. 7
11	Packing	Graphite with Braided end-rings			
12	Gland	A276 Type 410	A276 Type 410	A276 Type 410	A276 Type 316
13	Gland Flange	A216 Gr. WCC/ A105N	A217 Gr. WC6/ A182 Gr. F11	A217 Gr. WC9/ A182 Gr. F22	A217 Gr. C12A/ A182 Gr. F91
14	Gland Stud	A193 Gr. B7	A193 Gr. B16	A193 Gr. B16	A193 Gr. B16
15	Gland Nut	A194 Gr. 2H	A194 Gr. 7	A194 Gr. 7	A194 Gr. 7
16	Yoke	A216 Gr. WCC	A217 Gr. WC6	A217 Gr. WC9	A217 Gr. C12A
17	Stem Guide	A276 Type 410			
18	Stem Nut	Bronze			
19	Gear Unit	Ductile Iron			
20	Handwheel	Steel			
--	Identification Plate	SS 304			

HF - Hard-Faced with Stellite 6 or equivalent

Globe Valves - T Pattern - Dimensions & Weights

Size		Class 600				Class 900				Class 1500				Class 2500			
NPS	DN	A	B	C	Wt.	A	B	C	Wt.	A	B	C	Wt.	A	B	C	Wt.
2	50	292	425	228	40	216	575	406	65	216	550	406	85	279	750	508	155
3	80	356	540	305	65	305	590	406	75	305	690	500	170	368	712	486	240
4	100	432	610	457	165	356	675	630	130	406	710	630	280	457	800	710	340
6	150	559	805	710	270	508	795	710	350	559	920	900	530	610	1200	900	815
8	200	660	1135	900	645	660	1020	900	640	711	1280	710	915	762	1450	900	1400
10	250													914	1690	900	2150
16	400													1397	2435	1000	5555
18	450													1397	2645	1000	6900

Size		Class 3100			
NPS	DN	A	B	C	Wt.
2	50	279	850	400	230
3	80	368	1135	640	325
4	100	457	1000	710	650

Globe Valves - Y Pattern

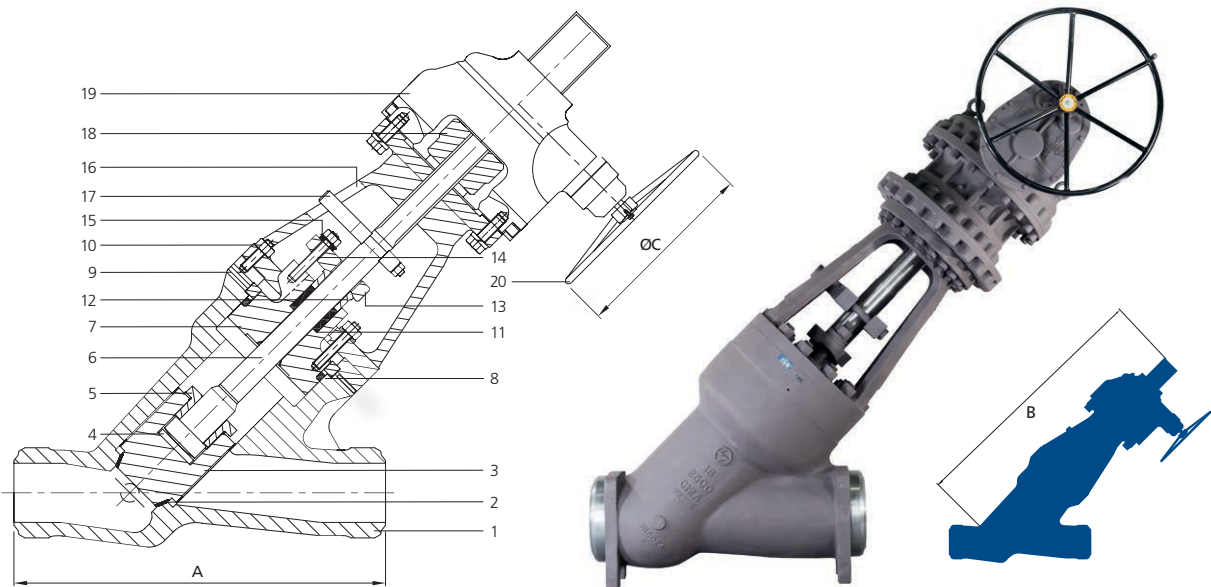

Dimensions & Weights

Size		Class 900				Class 1500				Class 2500			
NPS	DN	A	B	C	Wt.	A	B	C	Wt.	A	B	C	Wt.
2	50	368	620	406	60	368	620	406	60	451	620	406	110
3	80	381	630	508	80	470	710	400	110	578	875	630	185
4	100	457	865	500	170	546	875	630	170	673	920	710	330
6	150	610	1290	630	270	705	1200	900	410	914	1460	750	990
8	200	737	1710	710	610	832	1580	710	780	1022	1890	610	1900
10	250	838	1900	1000	830	991	1890	800	1375	1270	1960	900	2100
12	300	965	2080	1000	1300	1130	2040	900	2250	1041	2720	1000	3000
14	350	1029	2350	900	1550	1257	2390	1000	2570	1118	2760	710	4200
18	450	1219	2730	710	2800	1537	2900	1000	3500	1537	3020	1000	7150

All dimensions in mm and weights in kg

Check Valves - ASME Class 900 to 3500 (ASME B16.34)

L&T's high-pressure check valves are of pressure-seal design. As a standard, these valves are supplied with internal hinge-pins. Pressure-seal check valves can be offered in swing check design or tilting disc design.

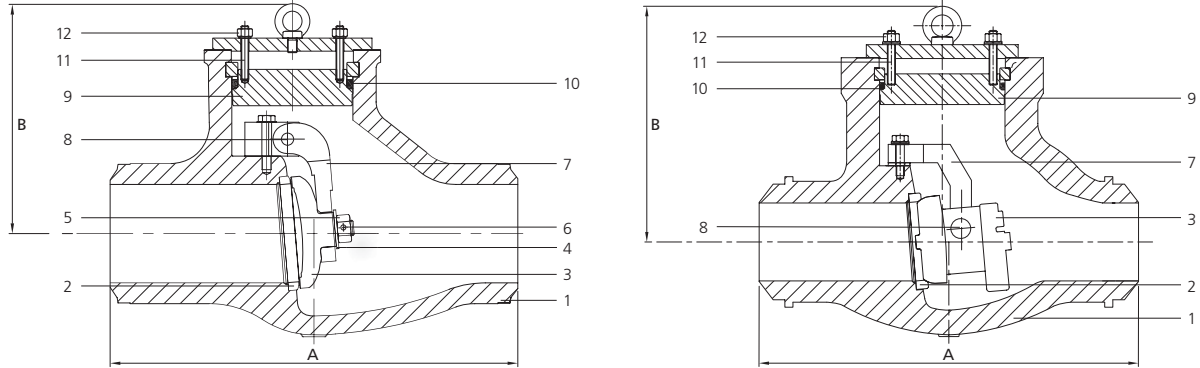

Materials of Construction

No.	Components	Materials			
		WCC	WC6	WC9	C12A
1	Body	A216 Gr. WCC	A217 Gr. WC6	A217 Gr. WC9	A217 Gr. C12A
2	Seat Ring	A105N + HF	A182 Gr. F11 +HF	A182 Gr. F22 + HF	A182 Gr. F91 + HF
3	Disc	A216 Gr. WCC/ A105N + HF	A217 Gr. WC6/ A182 Gr. F11 + HF	A217 Gr. WC9/ A182 Gr. F22 + HF	A217 Gr. C12A/ A182 Gr. F91 + HF
4	Disc Washer	SS 304/ SS 316			
5	Disc Nut	SS 304/ SS 316			
6	Disc Pin	SS 304/ SS 316			
7	Hinge/ Bracket	A216 Gr. WCC/ A516 Gr. 70	A217 Gr. WC6/ A387 Gr. 11	A217 Gr. WC9/ A387 Gr. 22	A217 Gr. C12A/ A387 Gr. 91
8	Hinge Pin/ Hinge Bolt	A276 Type 410			
9	Cover	A216 Gr. WCC/ A105N	A217 Gr. WC6/ A182 Gr. F11	A217 Gr. WC9/ A182 Gr. F22	A217 Gr. C12A/ A182 Gr. F91
10	Gasket	Graphite with Braided end-rings			
11	Cover Stud	A193 Gr. B7	A193 Gr. B16	A193 Gr. B16	A193 Gr. B16
12	Cover Nut	A194 Gr. 2H	A194 Gr. 7	A194 Gr. 7	A194 Gr. 7
--	Identification Plate	SS 304			

HF - Hard-Faced with Stellite 6 or equivalent

Swing Check Valve - Dimensions & Weights

Size		Class 900			Class 1500			Class 2500			Class 3100		
NPS	DN	A	B	Wt.	A	B	Wt.	A	B	Wt.	A	B	Wt.
2	50	216	230	35	216	230	35	279	240	45			
3	80	305	270	45	305	270	45	368	240	55	368	280	112
4	100	356	270	60	406	270	65	457	290	85	457	314	113
6	150	508	305	105	559	310	120	610	350	185	610	440	235
8	200	660	405	220	711	410	260	762	540	330	762	520	486
10	250	787	490	380	864	490	430	914	610	900	914	600	946
12	300	914	595	500	991	600	650	1041	650	1130	1041	706	1376
14	350	991	615	780	1067	615	830	1118	770	1460	1241	832	1700
16	400	1092	720	980	1194	700	1350	1245	825	1900	1245	778	2593
18	450	1219	800	1260	1346	770	1850	1397	900	2650	1395	861	3659
20	500	1321	900	2050	1664	915	2745	1473	950	3640	1524	933	4223
24	600	1549	1110	3375	1943	1110	3800	1549	1110	5500	1727	1041	6700

All dimensions in mm and weights in kg
Weights of Tilting Disc Check Valves available on demand

Customised Solutions

Bellow Seal Valves

Bellow Seal Valves are used in services where leakage through stem packing area needs to be eliminated. These valves find application in lines handling hazardous fluids in nuclear and thermal power as well as hydrocarbon industries. The bellows conform to MSS SP 117 and can be offered in stainless steel, Inconel or Hastelloy.



Reheater Isolating Device

Reheater Isolating Device (RID) is used to isolate reheater lines during hydrostatic tests. The device has a disc that can be inserted from the top between hard-faced seat rings to effect sealing. After hydrostatic tests, the disc is removed and the device effectively becomes an integral part of the piping. RID eliminates the need to physically isolate lines during tests.

The body-bonnet connection of this device is of pressure-seal design.

Quick Closing Non-return Valve

Quick Closing Non-Return Valves (QCNRV) are swing check valves where quick closing is achieved using special actuation mechanisms. These are used to protect turbines and compressors from damage due to back flow.

Vacuum Service Valves

Vacuum Service Valves are offered in a variety of sizes and pressure classes. Stem finish and integrity of gland packing are crucial for these valves. The valves can also be offered with lantern-ring arrangement based on customer demand.

Angle Globe Valves

In Angle Globe Valves, the inlet and outlet are at right angles to each other. These valves find application in lines where pipe configuration or pressure drop is a concern.

Angle Globe Valves can be offered in pressure-seal as well as bolted bonnet designs based on line pressure.

Stop Check Valve

Stop Check Valve is a Lift Check Valve with manual control, a Globe Valve with a free-floating disc not attached to stem.

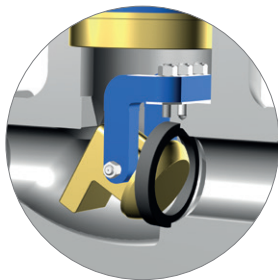

Tilting Disc Check Valve

Tilting Disc Check Valve is recommended for 'non-slam' applications. The disc in this valve is pivoted at the centre to avoid disc slamming and consequent damages.

Accessories

L&T Gate, Globe & Check Valves are supplied with a range of accessories to address process and plant requirements.

- Position Indicators
- Extension Spindle
- Locking Arrangement
- Live Loading

High pressure gate valves can be supplied with a variety of arrangements to equalize upstream and downstream pressures. Typically globe valves are used as bypass valves.

Further, to prevent centre cavity over-pressurization, the cavity is connected to the upstream side of the valve. This connection may be done with or without a pressure equalizing valve.

(For information on centre cavity relief, please refer ASME B16.34, Clause 2.3.3)



Type 1: Bypass Arrangement

The upstream and downstream sides of the valve are connected by a bypass pipe fitted with a globe valve. The gate valve is bidirectional.

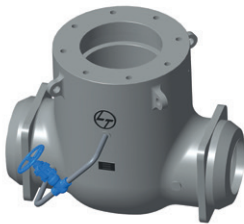

Type 2: Equalizing Arrangement

The centre cavity and upstream side of the valve are connected by a bypass pipe with a globe valve. The gate valve is unidirectional.



Type 3: Bypass and Equalizing Arrangement

There is an additional connection between centre cavity and upstream for cavity relief. The gate valve is unidirectional.



Type 4: Bypass and Equalizing Arrangement

The arrangement consists of a connection between the centre cavity and a bypass pipe, with one valve each on the upstream and downstream of the bypass pipe. Based on the flow direction, one valve can act as bypass valve and the other, as a pressure equalizing valve. The gate valve is thus bidirectional.



Type 5: Bypass and Equalizing Arrangement

The arrangement consists of a connection between the centre cavity and upstream side of the valve with an equalizing valve. The upstream and downstream sides of the valve are connected by a bypass pipe fitted with a globe valve. The gate valve is thus unidirectional.

Ordering Information

Size	Category	Class	End Connection	Material
NPS (DN)	F - Flex Wedge	6 - Class 600	6 - Butt-weld Ends	WCB
	P - Parallel Slide	9 - Class 900	3 - Flanged RF	WCC
	Y - Y Globe	A - Class 1500	5 - Flanged RTJ	WC6
	T - T Globe	B - Class 2500		WC9
	A - Angle Globe	C - Class 3100		C12A
	S - Swing Check			F91
	D - Tilting Disc			
	R - RID			



Gate, Globe & Check Valves - ASME Class 150 to 600

L&T offers a versatile range of cast steel gate, globe and check valves in bolted bonnet construction. The gate and globe valves are of outside screw-and-yoke design. The check valves are swing-type. This range is available with flanged and butt-weld ends and can be supplied with IBR certification.

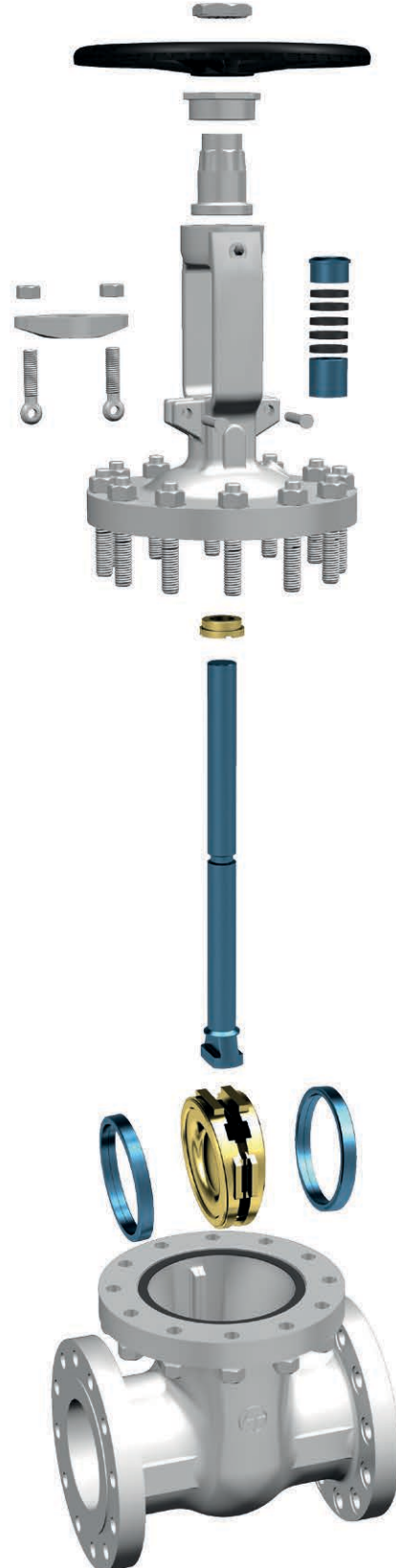

Stem

Single-piece forged stems are used in gate and globe valves for superior strength. In a gate valve, the forged T-head engages with a slot in the disc. The globe valve disc is fitted to the stem using a disc nut, which allows the disc to swivel and align with the seat.

Disc

Gate valve discs are of single-piece cast flexible wedge design. In these torque-seated valves, the flexible wedge compensates for seat distortion and eliminates disc-jamming.

Seat

In gate and check valves, seat rings are seal-welded to the body. This eliminates leakage path between seat ring and body as well as accidental loosening due to temperature fluctuations or vibrations.

Body-bonnet Joint

Class 150 gate valves in sizes 3" and above are offered with oval-shaped body-bonnet joints. As a standard, 2" gate valves as well as globe and check valves have circular body-bonnet joints.

Gate Valves - ASME Class 150, 300 & 600 (API 600, ASME B16.34)

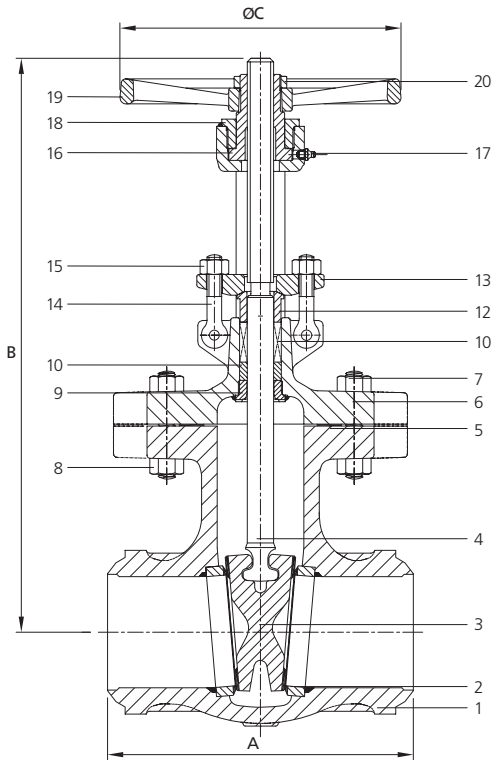

No.	Components	Materials
1	Body	A216 Gr. WCB
2	Seat Ring	A105N + HF
3	Wedge (Flexible)	A216 Gr. WCB + 13% Cr. Steel
4	Stem	A182 Gr. F6a
5	Gasket	Cl.150 Graphite with SS 316 Insert
		Cl.300 Spiral-wound SS 316 with Graphite filler
		Cl.600 RTJ - SS 316/ Soft Iron
6	Bonnet	A216 Gr. WCB
7	Stud	A193 Gr. B7
8	Hex Nut	A194 Gr. 2H
9	Backseat Ring	A276 Type 410
10	Spacer Ring	A276 Type 410
11	Packing	Graphite with braided end-rings
12	Gland	A276 Type 410
13	Gland Flange	A105N/ A216 Gr. WCB
14	Eye Bolt/ Stud	A193 Gr. B7
15	Hex Nut	A194 Gr. 2H
16	Stem Nut	A439 Type D2
17	Grease Fitting	Steel
18	Retainer Nut	
19	Handwheel	S.G Iron/ Steel
20	Handwheel Nut	
--	Identification Plate	SS 304

HF - Hard-Faced with Stellite 6 or equivalent
 Valves in other materials available on demand

Dimensions & Weights

NPS	DN	Class 150							Class 300					Class 600						
		A		B	ØC	Wt.		A		B	ØC	Wt.		A		B	ØC	Wt.		
		FL	BW			FL	BW	FL	BW			FL	BW	FL	BW			FL	BW	
2	50	178	216	360	203	21	19	216	216	370	203	25	23	292	292	400	203	42	36	
2.5	65	190	241	480	229	32	24	241	241	505	229	48	34							
3	80	203	282	480	229	35	27	282	282	505	229	53	41	356	356	540	254	67	63	
4	100	229	305	584	254	53	43	305	305	605	254	78	55	432	432	635	305	119	112	
5	125	254	381	750	254	75	64	381	381	850	356	135	105							
6	150	267	403	790	305	87	77	403	403	850	356	158	111	559	559	875	457	252	225	
8	200	292	419	996	356	139	118	419	419	1040	406	234	186	660	660	1225	500	465	410	
10	250	330	457	1205	406	210	198	457	457	1265	457	355	284	787	787	1465	630	700	600	
12	300	356	502	1410	457	302	271	502	502	1460	508	495	400	838	838	1695	630	970	855	
14	350	381	572	1540	508	410	365	762	762	1770	500	775	645	889	889	1830	710	1690	1555	
16	400	406	610	1900	500	550	520	838	838	1995	630	1010	900	991	991	2080	900	1835	1640	
18	450	432	660	2150	500	690	665	914	914	2320	710	1380	1145	1092	1092	2300	900	1980	1755	
20	500	457	711	2370	630	900	865	991	991	2500	710	1715	1600	1194	1194	2460	1000	3190	3000	
24	600	508	813	2650	630	1450	1400	1143	1143	2900	900	2600	2215	1397	1397	2940	1000	3620	3180	
26	650	559	864	2960	710	2010	1930	1245	1245	3005	900	3300	2534							
28	700	610	914	3100	800	2060	2184	1346	1346	3495	1000	4910	4751							
30	750	610	914	3335	800	3100	2473	1397	1397	3495	1000	5080	4760							
32	800	660	965	3540	900	3421	3345	1524	1524	3700	1000	5210	5116							
34	850	711	1016	3850	900	3774	3799	1626	1626	4000	800	6250	5943							
36	900	711	1016	3930	900	3980	3807	1727	1727	4175	800	6683	6055							
38	950	737	1042	4180	1000	4541	5119	1829	1829	4360	900	8500	8114							
40	1000	762	1059	4380	1000	5050	5598	1930	1930	4750	800	8605	8339							
42	1050	787	1092	4630	1000	6150	5275	1981	1981	4880	800	10530	10193							

All dimensions in mm and weights in kg

Globe Valves - ASME Class 150, 300 & 600 (BS1873, ASME B16.34)

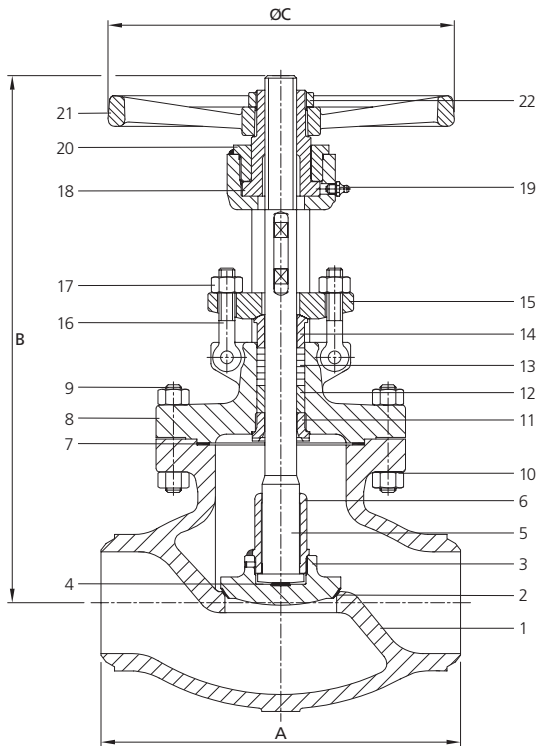

No.	Components	Materials	
1	Body	A216 Gr. WCB	
2	Seat	Insitu on Body + HF	
3	Disc (Plug Type)	A216 Gr. WCB + 13% Cr. Steel	
4	Disc Washer	A276 Type 410	
5	Stem	A182 Gr. F6a	
6	Disc Nut	A276 Type 410	
7	Gasket	Cl.150	Spiral-wound SS 316 with Graphite filler
		Cl.300	
		Cl.600	
8	Bonnet	A216 Gr. WCB	
9	Stud	A193 Gr. B7	
10	Hex Nut	A194 Gr. 2H	
11	Backseat Ring	A276 Type 410	
12	Spacer Ring	A276 Type 410	
13	Packing	Graphite with Braided end-rings	
14	Gland	A276 Type 410	
15	Gland Flange	A105N/ A216 Gr. WCB	
16	Eye Bolt/ Stud	A193 Gr. B7	
17	Hex Nut	A194 Gr. 2H	
18	Stem Nut (Yoke Sleeve)	A439 Type D2	
19	Grease Fitting	Steel	
20	Retainer Nut		
21	Handwheel	S.G Iron/ Steel	
22	Handwheel Nut		
--	Identification Plate	SS 304	

Valves in other materials available on demand

Globe Valves in sizes 10" and above are offered with insitu hardfaced integral seat rings

Dimensions & Weights

Size		Class 150							Class 300					Class 600					
		A		B	ØC	Wt.		A		B	ØC	Wt.		A		B	ØC	Wt.	
NPS	DN	FL	BW			FL	BW	FL	BW			FL	BW	FL	BW			FL	BW
2	50	203	203	380	203	23	20	267	267	415	203	33	28	292	292	475	254	42	38
3	80	241	241	460	254	41	38	318	318	515	254	58	50	356	356	585	356	75	60
4	100	292	292	535	305	66	62	356	356	605	356	97	84	432	432	665	406	136	116
6	150	406	406	610	356	118	110	444	444	715	457	186	164	559	559	1085	710	260	210
8	200	495	495	775	457	230	218	559	559	1185	710	410	375	660	660	1400	900	713	633
10	250	622	622	970	500	375	360	622	622	1290	900	700	650	787	787	1570	1000	1010	910
12	300	698	698	1195	710	495	470	711	711	1480	900	850	780	838	838	1810	800	1300	1110
14	350	787	787	1435	800	830	790	838	838	1700	1000	1100	982	889	889	1970	900	1690	1469
16	400	914	914	1570	800	1100	1047	864	864	1605	710	1650	1473	991	991	1615	800	2300	2000
18	450	978	978	1830	710	1620	1542	978	1040	1640	710	2000	1785	1092	1092	1790	900	2600	2260
20	500	978	978	1850	900	1620	1542	1016	1016	2370	1000	2500	2232						
24	600																		

All dimensions in mm and weights in kg

Check Valves - ASME Class 150, 300 & 600 (BS1868, ASME B16.34)

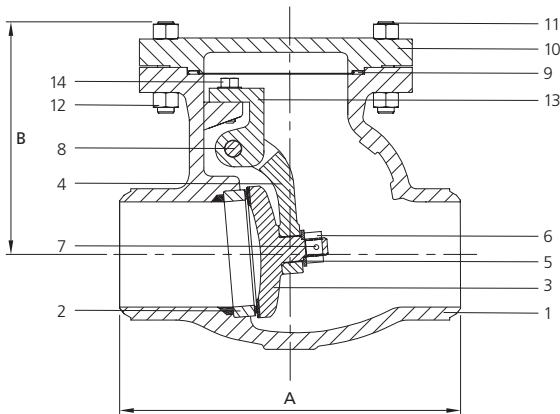

No.	Components	Materials	
1	Body	A216 Gr. WCB	
2	Seat Ring	A105N + HF	
3	Disc	A216 Gr. WCB + 13% Cr. Steel	
4	Hinge	A216 Gr. WCB	
5	Disc Washer	A276 Type 316	
6	Hinge		
7	Disc Nut Pin		
8	Hinge Pin	A276 Type 410	
9	Gasket	Cl.150	Spiral-wound SS 316 with Graphite filler
		Cl.300	
		Cl.600	
10	Cover	A216 Gr. WCB	
11	Stud	A193 Gr. B7	
12	Hex Nut	A194 Gr. 2H	
13	Bracket	A216 Gr. WCB	
14	Hex Head Screw	A276 Type 316	
--	Identification Plate	SS 304	

HF - Hard-Faced with Stellite 6 or equivalent

Valves in other materials available on demand

Dimensions & Weights

Size		Class 150					Class 300					Class 600				
		A		B	Wt.		A		B	Wt.		A		B	Wt.	
NPS	DN	FL	BW		FL	BW	FL	BW		FL	BW	FL	BW		FL	BW
2	50	203	203	150	21	19	267	267	160	24	19	292	292	180	35	30
3	80	241	241	180	34	27	318	318	190	45	36	356	356	205	55	46
4	100	292	292	215	49	43	356	356	230	70	56	432	432	250	92	70
6	150	356	356	270	88	77	444	444	315	151	129	559	559	330	204	161
8	200	495	495	325	168	118	533	533	370	242	210	660	660	415	323	260
10	250	622	622	405	333	198	622	622	410	333	284	787	787	500	550	455
12	300	698	698	455	413	271	711	711	485	450	378	838	838	575	790	680
14	350	787	787	490	509	365	838	838	540	659	556	889	889	610	870	790
16	400	864	864	530	580	490	864	864	575	873	747	991	991	670	1370	1260
18	450	978	978	590	635	665	978	978	680	1090	900	1092	1092	715	1750	1630
20	500	978	978	640	925	865	1016	1016	680	1360	1176	1194	1194	745	2360	2220
24	600	1295	1295	790	1500	1405	1346	1346	800	1850	1573	1397	1397	880	3820	3670
26	650	1295	1295	910	1276	1120	1346	1346	930	2375	1995					
28	700	1448	1448	850	2270	2160	1499	1499	1163	2660	2260					
30	750	1524	1524	1065	2575	2446	1594	1594	1120	3480	3320					
32	800	1700	1700	1150	2430	2130	1700	1700	1170	4000	3690					
34	850	1871	1871	1190	2780	2620	1955	1955	1230	4950	4750					
36	900	1956	1956	1225	3130	2930	2083	2083	1250	5350	5100					

All dimensions in mm and weights in kg

Operator Options

L&T Valves offers a variety of actuators and accessories to suit customer requirements.



Gear Unit

A gear unit is provided to reduce the effort required to operate the valve. A fully encased weather proof bevel gear is provided as standard. For applications with higher torque requirements, the bevel gear is supplemented with additional spur gear.



Pneumatic and Hydraulic

Pneumatic or Hydraulic actuators are selected for automation of valves for applications which require quick operating cycles.

Double Acting or Spring Return actuators can be supplied with various failsafe options.



Electric Operator

Electric actuators are selected for 'stay put' applications and are the most commonly used method of automation.

Electric actuators are suited for a variety of environmental conditions where power supply and communication protocol are available.

Ordering Information

Size	Valve Type	Class	End Connection	Trim Number
	1 - Gate	1 - 150	3 - Flanged RF	5 - Trim 5
	4 - Globe	3 - 300	5 - Flanged RTJ	8 - Trim 8
	7 - Check	6 - 600	6 - Butt-weld	12 - Trim 12
				16 - Trim 16



Body-bonnet Connection

The body-bonnet connection of these valves is of threaded construction. To enhance the seal, the body-bonnet joint is seal-welded.

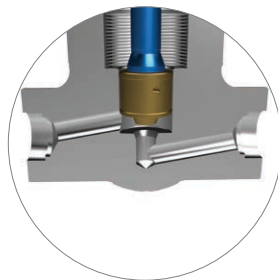

Stem-disc Assembly

The disc of a globe valve is connected to the stem using a wire inserted through a hole in the disc. This unique stem-disc connection enables the disc to rotate freely on the stem, align perfectly with the seat and produce a tight seal.

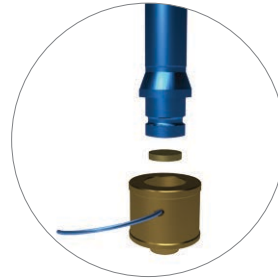

Seat and Disc

Forged steel valves have integral seats that are machined and hard-faced insitu for longer service life. As a standard, the valves are offered with 1.6 mm hard-facing.

The discs are guided during opening/ closing to ensure proper sealing and to minimize seat damage.

Forged Steel Globe Valves - ASME Class 1500, 2500 & 4500 (ASME B16.34)

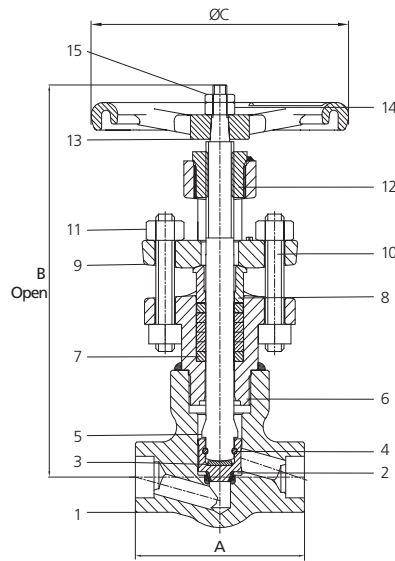

Dimensions & Weights

Size		Class 1500/ 2500				Class 4500			
NPS	DN	A	B	ØC	Wt.	A	B	ØC	Wt.
½	15	115	265	175	8	130	285	175	11
¾	20	115	265	175	8	130	285	175	11
1	25	130	290	225	10	165	320	225	16
1 ¼	32	178	375	275	18	188	410	275	29
1 ½	40	178	375	275	18	188	410	275	29
2	50	202	430	300	28	230	437	300	50

All dimensions in mm and weights in kg

Valves in ASME Classes 1500 & 2500 are available in sizes up to 2"

Materials of Construction

No.	Components	Materials			
		A105	F22	F91	F304
1	Body (Integral Seat)	A105	A182 Gr. F22 Cl. 3	A182 Gr. F91	A182 Gr. F304
2	Disc	A479 Type 410 + HF	A479 Type 410 + HF	A479 Type 316 + HF	A479 Type 316 + HF
3	Disc Washer	A479 Type 410	A479 Type 410	A479 Type 431	A479 Type XM19
4	Retainer Wire	A479 Type 430	A479 Type 430	A479 Type 430	A479 Type 316
5	Stem	A182 Gr. F6a	A182 Gr. F6a	A479 Type XM19	A479 Type XM19
6	Bonnet	A105	A182 Gr. F22 Cl. 3	A182 Gr. F91	A182 Gr. F304
7	Packing	Die-moulded Graphite Packing with Braided end-rings			
8	Gland	A276 Type 410		A276 Type 316	
9	Gland Flange	A105	A105	A105	A182 Gr. F304
10	Stud	A193 Gr. B7	A193 Gr. B16	A193 Gr. B16	A193 Gr. B8 Cl. 1
11	Heavy Hex Nut	A194 Gr. 2H	A194 Gr. 7	A194 Gr. 7	A194 Gr. 8
12	Yoke Bush	B148	B148	B148	Aluminium Bronze
13	Handwheel	IS 1865 Gr. SG400/ 15			
14	Heavy Hex Nut	A194 Gr. 2H	A194 Gr. 7	A194 Gr. 7	A194 Gr. 8
15	Lock Nut	A194 Gr. 2H	A194 Gr. 7	A194 Gr. 7	A194 Gr. 8
--	Identification Plate	Stainless Steel			

HF - Hard-Faced with Stellite 6 or equivalent

Forged Steel Check Valves - ASME Class 1500, 2500 & 4500 (ASME B16.34)

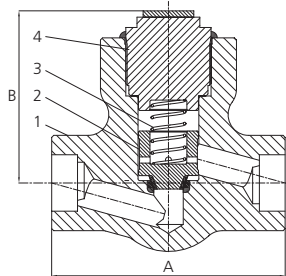

Dimensions & Weights

Size		Class 1500/ 2500			Class 4500		
NPS	DN	A	B	Wt.	A	B	Wt.
½	15	115	83	3	130	77	5
¾	20	115	83	3	130	77	5
1	25	130	92	5	165	97	9
1 ¼	32	178	122	9	188	127	18
1 ½	40	178	122	9	188	127	18
2	50	202	136	14	230	146	30

All dimensions in mm and weights in kg

Valves in ASME Classes 1500 & 2500 are available in sizes up to 2"

Materials of Construction

No.	Components	Materials			
		A105	F22	F91	F304
1	Body (Integral Seat)	A105	A182 Gr. F22 Cl. 3	A182 Gr. F91	A182 Gr. F304
2	Disc	A479 Type 410 + HF	A479 Type 410 + HF	A479 Type 316 + HF	A479 Type 316 + HF
3	Spring	Inconel X750			
4	Cover	A105	A182 Gr. F22 Cl. 3	A182 Gr. F91	A182 Gr. F304
--	Identification Plate	Stainless Steel			

HF - Hard-Faced with Stellite 6 or equivalent

Ordering Information

Series	Type	Class	Ends	API Trim
L	F - Forged Steel Globe	A - 1500	L - Socket weld	5 - Trim 5
	L - Forged Steel Check	B - 2500	B - Butt-weld	16 - Trim 16
		F - 4500		

Pressure Temperature Table - Special Class (ASME B16.34, 2013)

Temp in °C	WCB, LF2, A105						
	Working Pressures by Class, bar						
	150	300	600	900	1500	2500	4500
-29 to 38	19.8	51.7	103.4	155.1	258.6	430.9	775.7
50	19.8	51.7	103.4	155.1	258.6	430.9	775.7
100	19.8	51.6	103.3	154.9	258.2	430.3	774.5
150	19.6	51.0	102.1	153.1	255.2	425.3	765.5
200	19.4	50.6	101.1	151.7	252.9	421.4	758.6
250	19.4	50.5	101.1	151.6	252.6	421.1	757.9
300	19.4	50.5	101.1	151.6	252.6	421.1	757.9
325	19.2	50.1	100.2	150.3	250.6	417.6	751.7
350	18.7	48.9	97.8	146.7	244.6	407.6	733.7
375	18.1	47.1	94.2	141.3	235.5	392.5	706.5
400	16.6	43.4	86.8	130.2	217.0	361.7	651.0
425	13.8	36.0	71.9	107.9	179.8	299.6	539.3
450	11.0	28.8	57.5	86.3	143.8	239.6	431.4
475	8.4	21.8	43.6	65.4	109.0	181.6	326.9
500	5.6	14.7	29.4	44.1	73.5	122.4	220.4
538	2.8	7.4	14.8	22.2	36.9	61.6	110.8

Temp in °C	WCC, LCC						
	Working Pressures by Class, bar						
	150	300	600	900	1500	2500	4500
-29 to 38	20.0	51.7	103.4	155.1	258.6	430.9	775.7
50	20.0	51.7	103.4	155.1	258.6	430.9	775.7
100	20.0	51.7	103.4	155.1	258.6	430.9	775.7
150	20.0	51.7	103.4	155.1	258.6	430.9	775.7
200	20.0	51.7	103.4	155.1	258.6	430.9	775.7
250	20.0	51.7	103.4	155.1	258.6	430.9	775.7
300	20.0	51.7	103.4	155.1	258.6	430.9	775.7
325	20.0	51.7	103.4	155.1	258.6	430.9	775.7
350	19.8	51.1	102.2	153.3	255.5	425.8	766.4
375	19.3	48.4	96.7	145.1	241.9	403.1	725.6
400	19.3	43.4	86.8	130.2	217.0	361.7	651.0
425	18.0	36.0	71.9	107.9	179.8	299.6	539.3
450	14.4	28.8	57.5	86.3	143.8	239.6	431.4
475	10.7	21.4	42.7	64.1	106.8	178.0	320.4
500	7.2	14.5	29.0	43.4	72.4	120.7	217.2
538	3.7	7.4	14.8	22.2	36.9	61.6	110.8

Temp in °C	LCB						
	Working Pressures by Class, bar						
	150	300	600	900	1500	2500	4500
-29 to 38	20.0	48.0	96.0	144.1	240.1	400.1	720.3
50	20.0	48.0	96.0	144.1	240.1	400.1	720.3
100	20.0	48.0	96.0	144.1	240.1	400.1	720.3
150	20.0	48.0	96.0	144.1	240.1	400.1	720.3
200	20.0	48.0	96.0	144.1	240.1	400.1	720.3
250	20.0	48.0	96.0	144.1	240.1	400.1	720.3
300	20.0	48.0	96.0	144.1	240.1	400.1	720.3
325	20.0	48.0	95.9	143.9	239.8	399.6	719.3
350	19.8	47.3	94.6	141.9	236.5	394.1	709.4
375	19.3	44.9	89.9	134.8	224.7	374.6	674.2
400	19.3	40.8	81.6	122.3	203.9	339.8	611.7
425	17.1	34.1	68.3	102.4	170.6	284.4	511.9
450	13.5	27.0	54.0	81.0	134.9	224.9	404.8
475	9.8	19.6	39.2	58.8	97.9	163.2	293.8
500	6.9	13.8	27.7	41.5	69.2	115.3	207.6
538	3.7	7.4	14.8	22.2	36.9	61.6	110.8

Temp in °C	WC6, F11						
	Working Pressures by Class, bar						
	150	300	600	900	1500	2500	4500
-29 to 38	19.8	51.7	103.4	155.1	258.6	430.9	775.7
50	19.8	51.7	103.4	155.1	258.6	430.9	775.7
100	19.8	51.7	103.4	155.1	258.6	430.9	775.7
150	19.8	51.7	103.4	155.1	258.6	430.9	775.7
200	19.8	51.7	103.4	155.1	258.6	430.9	775.7
250	19.8	51.7	103.4	155.1	258.6	430.9	775.7
300	19.8	51.7	103.4	155.1	258.6	430.9	775.7
325	19.8	51.7	103.4	155.1	258.6	430.9	775.7
350	19.8	51.5	102.8	154.3	257.1	428.6	771.4
375	19.3	50.6	101.0	151.5	252.5	420.9	757.4
400	19.3	50.3	100.6	150.6	251.2	418.3	753.2
425	19.0	49.6	99.3	148.9	248.2	413.7	744.6
450	18.1	47.3	94.4	141.4	235.8	393.1	707.6
475	16.4	42.8	85.5	128.2	213.7	356.3	641.3
500	12.3	32.2	64.3	96.5	160.8	268.0	482.4
538	7.1	18.6	37.2	55.8	93.1	155.1	279.2
550	6.1	15.9	31.8	47.7	79.4	132.4	238.3
575	4.2	11.0	22.0	33.0	55.0	91.7	165.1
600	2.9	7.6	15.3	22.9	38.2	63.6	114.5
625	2.0	5.3	10.6	16.0	26.6	44.4	79.9
650	1.4	3.5	7.1	10.6	17.7	29.5	53.2

Temp in °C	WC9, F22						
	Working Pressures by Class, bar						
	150	300	600	900	1500	2500	4500
-29 to 38	19.8	51.7	103.4	155.1	258.6	430.9	775.7
50	19.8	51.7	103.4	155.1	258.6	430.9	775.7
100	19.8	51.6	103.2	154.9	258.1	430.2	774.3
150	19.5	51.0	101.9	152.9	254.8	424.6	764.3
200	19.3	50.2	100.4	150.7	251.1	418.5	753.4
250	19.2	50.0	100.0	149.9	249.9	416.5	749.7
300	19.1	49.8	99.6	149.3	248.9	414.8	746.7
325	19.0	49.6	99.2	148.8	248.0	413.3	743.9
350	18.9	49.2	98.4	147.6	246.0	410.0	738.1
375	18.7	48.8	97.5	146.3	243.8	406.3	731.3
400	18.7	48.8	97.5	146.3	243.8	406.3	731.3
425	18.7	48.8	97.5	146.3	243.8	406.3	731.3
450	18.1	47.3	94.4	141.4	235.8	393.1	707.6
475	16.4	42.8	85.5	128.2	213.7	356.3	641.3
500	13.7	35.6	71.5	107.1	178.6	297.5	535.4
538	8.8	23.0	46.1	69.1	115.2	192.1	345.7
550	7.5	19.5	39.1	58.6	97.7	162.8	293.1
575	5.0	13.2	26.3	39.5	65.8	109.7	197.4
600	3.3	8.6	17.2	25.8	43.0	71.7	129.1
625	2.1	5.6	11.2	16.7	27.9	46.5	83.7
650	1.4	3.5	7.1	10.6	17.7	29.5	53.2

Temp in °C	C12A, F91						
	Working Pressures by Class, bar						
	150	300	600	900	1500	2500	4500
-29 to 38	20.0	51.7	103.4	155.1	258.6	430.9	775.7
50	20.0	51.7	103.4	155.1	258.6	430.9	775.7
100	20.0	51.7	103.4	155.1	258.6	430.9	775.7
150	20.0	51.7	103.4	155.1	258.6	430.9	775.7
200	20.0	51.7	103.4	155.1	258.6	430.9	775.7
250	20.0	51.7	103.4	155.1	258.6	430.9	775.7
300	20.0	51.7	103.4	155.1	258.6	430.9	775.7
325	20.0	51.7	103.4	155.1	258.6	430.9	775.7
350	19.8	51.5	102.8	154.3	257.1	428.6	771.4
375	19.3	50.6	101.0	151.5	252.5	420.9	757.4
400	19.3	50.3	100.6	150.6	251.2	418.3	753.2
425	19.0	49.6	99.3	148.9	248.2	413.7	744.6
450	18.1	47.3	94.4	141.4	235.8	393.1	707.6
475	16.4	42.8	85.5	128.2	213.7	356.3	641.3
500	13.7	35.6	71.5	107.1	178.6	297.5	535.4
538	11.0	29.0	57.9	86.9	145.1	241.7	435.1
550	11.0	29.0	57.9	86.9	145.1	241.7	435.1
575	10.9	28.6	57.1	85.7	143.0	238.3	428.8
600	9.3	24.4	48.7	73.1	121.9	203.1	365.6
625	7.0	18.3	36.5	54.8	91.3	152.1	273.8
650	4.8	12.4	24.8	37.2	62.1	103.4	186.2

Temp in °C	CF8, F304						
	Working Pressures by Class, bar						
	150	300	600	900	1500	2500	4500
-29 to 38	19.8	51.7	103.4	155.1	258.6	430.9	775.7
50	19.4	50.5	101.0	151.5	252.5	420.8	757.4
100	17.5	45.6	91.2	136.8	228	380.0	683.9
150	15.8	41.3	82.6	123.9	206.5	344.2	619.6
200	14.8	38.5	77.0	115.4	192.4	320.7	577.2
250	13.9	36.3	72.5	108.8	181.3	302.2	543.9
300	13.2	34.5	69.0	103.5	172.5	287.5	517.5
325	12.9	33.7	67.5	101.2	168.7	281.1	506.0
350	12.7	33.1	66.1	99.2	165.3	275.5	496.0
375	12.4	32.4	64.8	97.2	162.0	270.0	486.0
400	12.2	31.7	63.5	95.2	158.7	264.5	476.1
425	12.0	31.2	62.5	93.7	156.2	260.4	468.7
450	11.7	30.6	61.2	91.8	153.0	254.9	458.9
475	11.5	30.1	60.1	90.2	150.3	250.5	450.9
500	11.3	29.6	59.1	88.7	147.8	246.4	443.5
538	11.0	28.6	57.3	85.9	143.1	238.5	429.4
550	10.9	28.4	56.8	85.1	141.9	236.5	425.7
575	10.0	26.1	52.1	78.2	130.3	217.2	390.9
600	8.1	21.1	42.2	63.3	105.5	175.8	316.5
625	6.6	17.2	34.5	51.7	86.2	143.6	258.5
650	5.4	14.1	28.2	42.2	70.4	117.3	211.2
675	4.5	11.7	23.4	35.1	58.4	97.4	175.3
700	4.1	10.7	21.3	32.0	53.3	88.9	160.0
725	3.5	9.2	18.5	27.7	46.2	77.0	138.6
750	2.8	7.4	14.8	22.1	36.7	61.2	110.3
775	2.2	5.8	11.4	17.2	28.5	47.6	85.6
800	1.8	4.4	8.8	13.2	22.0	36.6	65.6
816	1.4						

Flange, Butt-Weld & Socket Weld Dimensions

Flanged Dimensions as per ASME B16.5, 2013

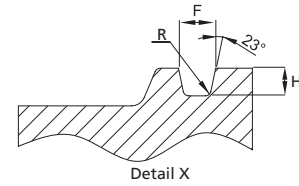
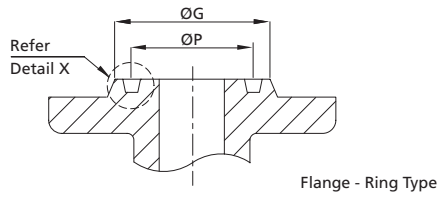
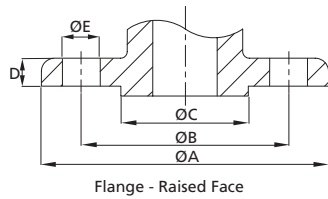

Size		ASME Class 150 Raised Face (in mm)							ASME Class 300 Raised Face (in mm)						
NPS	DN	ØA	ØB	ØC	D	ØE	Bolt		ØA	ØB	ØC	D	ØE	Bolt	
							No.	Dia						No.	Dia
2	50	150	120.7	92.1	14.3	¾"	4	⅝"	165	127.0	92.1	20.7	¾"	8	⅝"
2.5	65	180	139.7	104.8	15.9	¾"	4	⅝"	190	149.2	104.8	23.9	⅞"	8	¾"
3	80	190	152.4	127.0	17.5	¾"	4	⅝"	210	168.3	127.0	27.0	⅞"	8	¾"
4	100	230	190.5	157.2	22.3	¾"	8	⅝"	255	200.0	157.2	30.2	⅞"	8	¾"
5	125	255	215.9	185.7	22.3	⅞"	8	¾"	280	235.0	185.7	33.4	⅞"	8	¾"
6	150	280	241.3	215.9	23.9	⅞"	8	¾"	320	269.9	215.9	35.0	⅞"	12	¾"
8	200	345	298.5	269.9	27.0	⅞"	8	¾"	380	330.2	269.9	39.7	1"	12	⅞"
10	250	405	362.0	323.8	28.6	1"	12	⅞"	445	387.4	323.8	46.1	1 ⅛"	16	1"
12	300	485	431.8	381.0	30.2	1"	12	⅞"	520	450.8	381.0	49.3	1 ¼"	16	1 ⅛"
14	350	535	476.3	412.8	33.4	1 ⅛"	12	1"	585	514.4	412.8	52.4	1 ¼"	20	1 ⅛"
16	400	595	539.8	469.9	35.0	1 ⅛"	16	1"	650	571.5	469.9	55.6	1 ⅜"	20	1 ¼"
18	450	635	577.9	533.4	38.1	1 ¼"	16	1 ⅛"	710	628.6	533.4	58.8	1 ⅜"	24	1 ¼"
20	500	700	635.0	584.2	41.3	1 ¼"	20	1 ⅛"	775	685.8	584.2	62.0	1 ⅜"	24	1 ¼"
24	600	815	749.3	692.2	46.1	1 ⅜"	20	1 ¼"	915	812.8	692.2	68.3	1 ⅝"	24	1 ½"

Height of raised face is 2 mm.

Size		ASME Class 600 Raised Face							ASME Class 600 Ring Type						
NPS	DN	ØA	ØB	ØC	D	ØE	Bolt		ØG	Groove Number	ØP	Depth H	Width F	Bottom Rad. R	
							No	Dia							
2	50	165	127.0	92.1	25.4	¾"	8	⅝"	108	R23	82.55	7.92	11.91	0.8	
3	80	210	168.3	127.0	31.8	⅞"	8	¾"	146	R31	123.83	7.92	11.91	0.8	
4	100	275	215.9	157.2	38.1	1"	8	⅞"	175	R37	149.23	7.92	11.91	0.8	
6	150	355	292.1	215.9	47.7	1 ⅛"	12	1"	241	R45	211.12	7.92	11.91	0.8	
8	200	420	349.2	269.9	55.6	1 ¼"	12	1 ⅛"	302	R49	269.88	7.92	11.91	0.8	
10	250	510	431.8	323.8	63.5	1 ⅜"	16	1 ¼"	356	R53	323.85	7.92	11.91	0.8	
12	300	560	489.0	381.0	66.7	1 ⅜"	20	1 ¼"	413	R57	381.00	7.92	11.91	0.8	
14	350	605	527.0	412.8	69.9	1 ½"	20	1 ⅜"	457	R61	419.10	7.92	11.91	0.8	
16	400	685	603.2	469.9	76.2	1 ⅝"	20	1 ½"	508	R65	469.90	7.92	11.91	0.8	
18	450	745	654.0	533.4	82.6	1 ¾"	20	1 ⅝"	575	R69	533.40	7.92	11.91	0.8	
20	500	815	723.9	584.2	88.9	1 ¾"	24	1 ⅝"	635	R73	584.20	9.53	13.49	1.5	
24	600	940	838.2	692.2	101.6	2"	24	1 ⅞"	749	R77	692.15	11.13	16.66	1.5	

Height of raised face is 7 mm each

Flanged as per ASME B16.47, 2011 Series A (MSS SP 44) & Series B (API 605)

ASME Class	Size		Series A (MSS SP 44)							Series B (API 605)						
	NPS	DN	ØA	ØB	ØC	D	ØE	Bolt		ØA	ØB	ØC	D	ØE	Bolt	
								No	Dia						No	Dia
Cl.150	28	700	925	863.6	800	69.9	1 ⅜"	28	1 ¼"	835	795.3	762	43.0	⅞"	40	¾"
	30	750	985	914.4	857	73.1	1 ⅜"	28	1 ¼"	885	846.1	813	43.0	⅞"	44	¾"
	34	850	1110	1028.7	965	81.0	1 ⅝"	32	1 ½"	1005	957.3	921	47.7	1"	40	⅞"
	36	900	1170	1085.8	1022	88.9	1 ⅝"	32	1 ½"	1055	1009.6	972	50.9	1"	44	⅞"
	42	1050	1240	1149.4	1073	85.8	1 ⅝"	36	1 ½"	1125	1070.0	1022	52.5	1 ⅛"	40	1"

Height of raised face is 2 mm

Butt-weld Ends as per ASME B16.25, 2012 (Welding end detail for joint without backing ring)

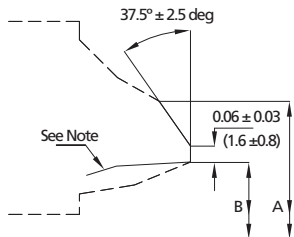

For wall thickness less than 22 mm (0.88").

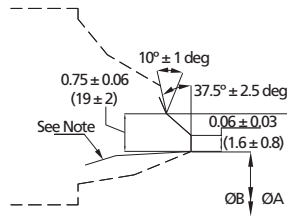

For wall thickness greater than 22 mm (0.88").

Note : Internal surface may be reformed or machined for dimensions B at root face. Contour within the envelope is manufacturer's option, unless otherwise specifically ordered for.

Size		ØA	ØB										
NPS	DN		STD	XS	30	40	60	80	100	120	140	160	XXS
2	50	62	52.5	49.3	-	52.5		49.3				42.8	38.2
2.5	65	75	62.5	59.0	63.5	62.5		59.0				54.0	45.0
3	80	91	78.0	73.5	79.5	78.0		73.5				66.5	58.5
4	100	117	102.0	97.0	104.5	102.0		97.0		92.0		87.5	80.0
5	125	144	128.0	122.0		128.0		122.0		116.0		109.5	103.0
6	150	172	154.0	146.5		154.0		146.5		140.0		132.0	124.5
8	200	223	203.0	193.5	205.0	203.0	198.5	193.5	189.0	182.5	178.0	173.0	174.5
10	250	278	254.5	247.5	257.5	254.5	247.5	243.0	236.5	230.0	222.0	216.0	222.0
12	300	329	305.0	298.5	307.0	303.0	295.0	289.0	281.0	273.0	266.5	257.0	273.0
14	350	362	336.5	330.0	336.5	333.5	325.5	317.5	308.0	300.0	292.0	284.0	
16	400	413	387.5	381.0	387.5	381.0	373.0	363.5	354.0	344.5	333.5	325.5	
18	450	464	438.0	432.0	435.0	428.5	419.0	409.5	398.5	387.5	378.0	366.5	
20	500	516	489.0	482.5	482.5	478.0	467.0	455.5	443.0	432.0	419.0	408.0	
24	600	619	590.5	584.0	581.0	574.5	560.5	547.5	532.0	517.5	505.0	490.5	
26	650	670	641.3	635.0									
28	700	721	692.1	686.0	679.5								
30	750	772	742.9	736.5	730.0								
32	800	825	793.7	787.5	781.0	778.0							
34	850	876	844.5	838.0	832.0	828.5							
36	900	927	895.3	889.0	882.5	876.5							
38	950	978	946.0	940.0									
40	1000	1029	997.0	990.5									
42	1050	1079	1047.5	1041.5									
44	1100	1130	1098.5	1092.0									
46	1150	1181	1149.5	1143.0									
48	1200	1232	1200.0	1194.0									

Socket Weld details and table as per ASME B16.11 - 2011

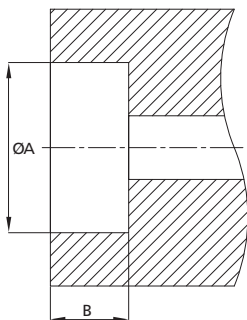

Size		Socket Bore ØA	Socket Depth B
NPS	DN		
½	15	21.8	9.7
¾	20	27.2	12.7
1	25	33.9	12.7
1 ¼	32	42.7	12.7
1 ½	40	48.8	12.7
2	50	61.2	16.2

All dimensions in mm



L&T Valves Limited

Mount - Poonamallee Road, Manapakkam, Chennai 600 089, INDIA

Tel. : + 91 44 2249 8201 Email: ContactUs@Lntvalves.com www.Lntvalves.com CIN Number: U74999MH1961PLC012188

Registered Office: L&T House, N. M. Marg, Ballard Estate, Mumbai - 400 001, INDIA

Publication Number: VC002/1116

As we continuously endeavour to improve our products, the data given herein is subject to change.
Please refer www.Lntvalves.com for the latest publication.

